

# BAKKO BAK BORD

## 8' x 12' ECONOMY FLAT SERIES INSTRUCTIONS

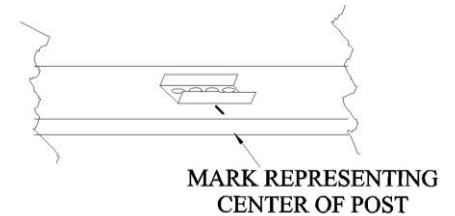

**STEP ONE:** Standard installation mounts backboard one foot off ground. Mount 2 x 4's to post by centering and bolting three 12' pressure treated 2 x 4's on two posts with 8" long bolts and back post braces, parallel above the ground 2', 5' and 8'. Measure from ground to center of each 2 x 4. (**Fig 1**) Hold 2x4 in location to be bolted on posts. Draw lines on 2 x 4's corresponding to center of each post. Using back post brace as a guide, mark where bolts will go through middle of 2 x 4 on either side of post lines. Drill 7/16" holes at each of these marks. Use 2 x 4 as a template to drill 4 holes in other 2 x 4's. Insert 8" bolts through 2 x 4's, fence mesh and back post braces. Secure with washers and nuts. Tighten back post brace and 2x4 with bolt around post. Cut off excess of bolts with hacksaw. (Extra long bolts provided to accommodate most diameter post) Check if 2x4's are level and plumb with 4' level. Mount three 12' 2x4's as described above and using **Fig 1**.

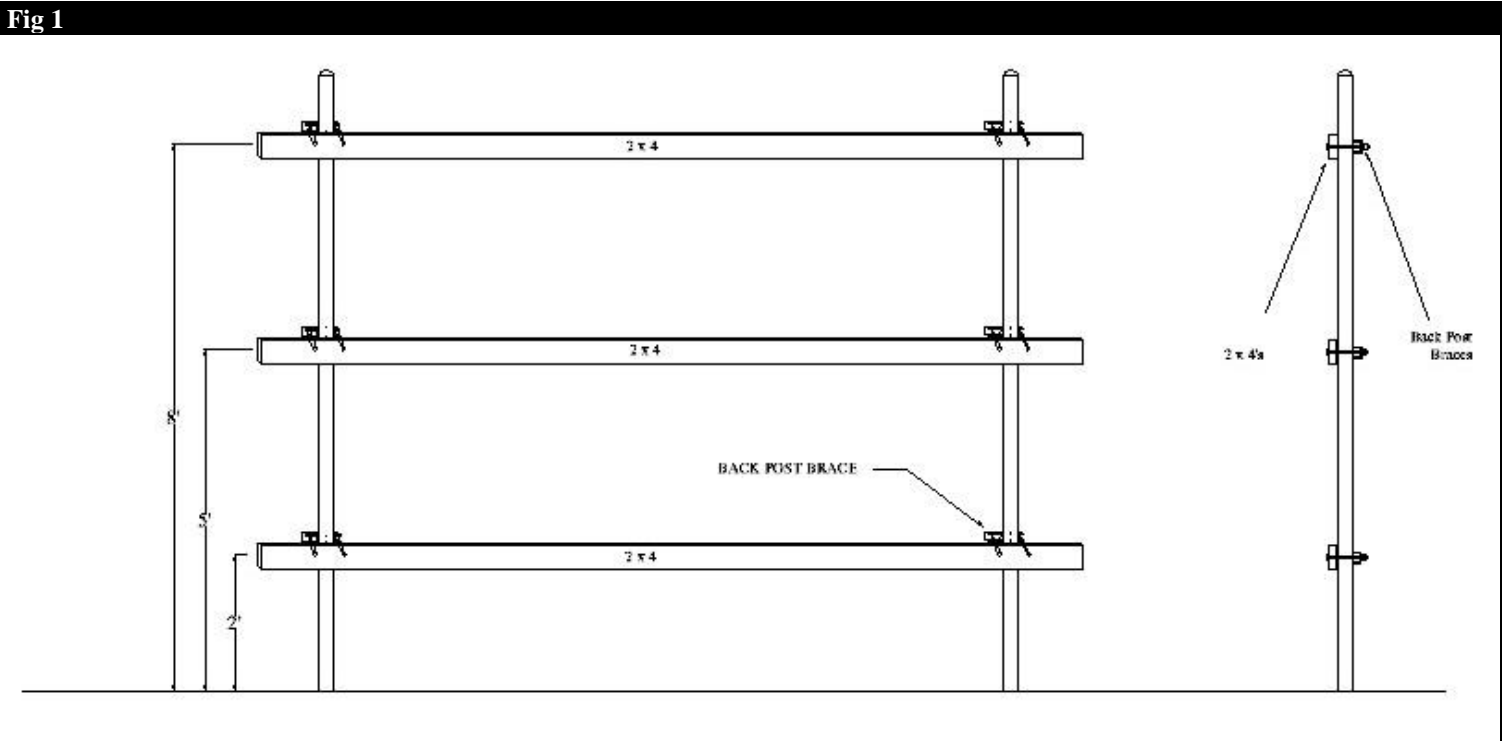

*Bakko Bak Bord strongly recommends building a temporary platform exactly one foot high- use cinderblocks and some old flat long boards--to place panels on when mounting . Platform simplifies installation and assembly from sagging under weight of panels. Sagging will not occur once panels are bolted in place. (**Fig 2**)*

NOTE: If there are more than 2 posts, position 2 x 4's, holes & panels so panel bolts do not interfere with back post braces or posts. If panels are centered on two posts approximately 10 feet apart, there is not a problem.

**STEP TWO:** Center any one panel halfway between ends of 2 x 4's (**measure very carefully or 2 x 4's will not be long enough on one end**). Place panel on platform. Hold it flush against 2 x 4's mounted to fence. Use 4' level to check if panel is level and plumb. With naked eye judgment, drill 7/16" holes through front of panel face and 2 x 4 behind; at top, middle and bottom on both sides. (**1" inside edges of panel Fig 2**) Center holes to the middle of 2 x 4's assuring level panel. Insert 4" flat head 3/8" bolts through panel and 2 x 4's. Put washers and nuts on back. Gently snug up. Pound flat head bolt with a large headed hammer and wood block (*Bakko recommends a rubber mallet.*) just enough to lock into fiberglass front. Further tighten nut. Pounding and tightening allows bolt to snug in front and won't crack fiberglass. Avoid missing bolt and denting front of panel. **Do not use metal hammer on bolt heads, this will chip paint!**

Fig 2

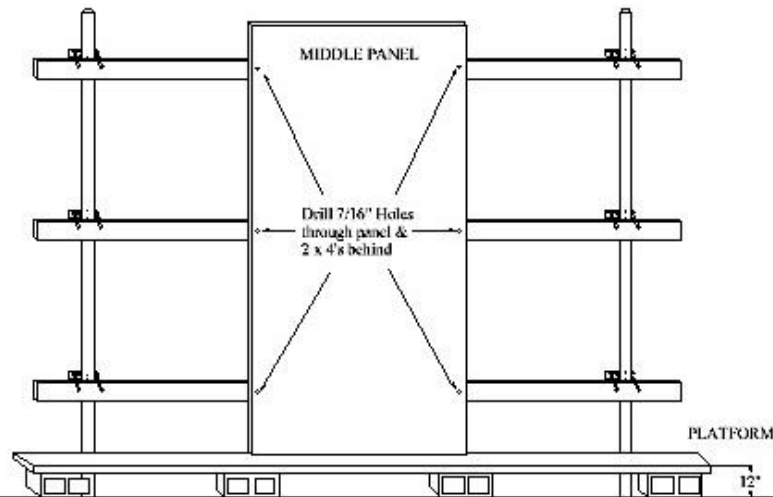

**STEP THREE:** Put weather stripping on **both** side edges of panel, from top to bottom, approximately 1/8" in from back edge of panel. (**Fig 3**)

**STEP FOUR:** Mount side panels. Set another panel on platform, while stronger of two men push panel against weather strip of middle panel. Once panels are even and flush, drill holes. Insert and tighten bolts like center panel. Add last panel in similar fashion. (**Fig 4**)

Fig 3

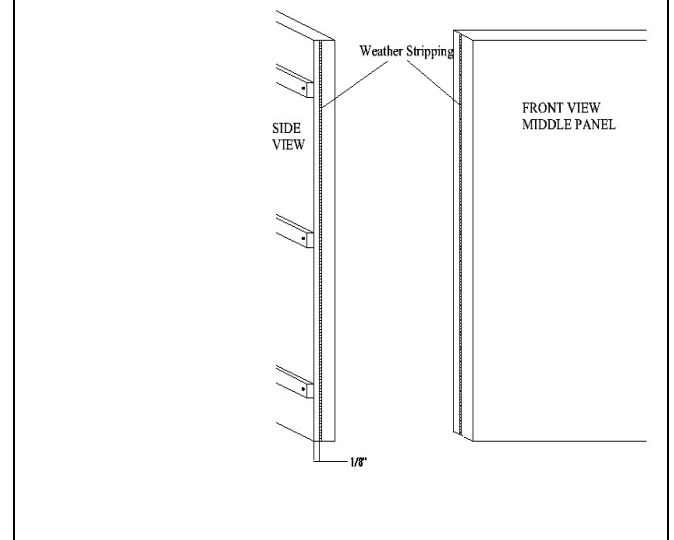

**STEP FIVE:** Put white line on -- **PLEASE** -- it really adds class!! Wipe panels with a cloth, notably in line area. Put small pencil mark 36" above ground in exact center of middle panel. Similarly mark two end panels at 37". (*Bakko recommends the use of a chalk line to connect inner and outer marks*) This indicates top of tape line. (**Fig 4**)

The white tape is a very expensive automotive trim tape. Applied properly it will last many years. There are **TWO LAYERS**: back thick paper layer and thin white layer. Separate layers for one inch to assure identification. Pull off back layer while slowly applying tape to the backboard. Pulling tape snug (do not over stretch tape, this will cause a wavy line), apply to center mark and go to one edge. Remove back layer and apply tape carefully. Do not apply in a strong wind or high temperatures. Once at edge of backboard, cut tape. Rub top edge of tape with fingers or preferably a drivers license or credit card. Try to prevent air bubbles from forming. **Once on, do not try to remove tape!** (If air bubbles form, eliminate by making a small puncture with nail or knife tip). Iron air toward hole with finger. Repeat steps with the rest of the roll of tape to complete other side. Slice tape at joints of panels and fold between panels. Cut a 4" long piece of tape and apply vertically in the middle for a center strip. (**Fig. 4**) **If our instructions are clear and you like our product, reward us by applying our logo on edge of the new backboard.**

**Fig 4**

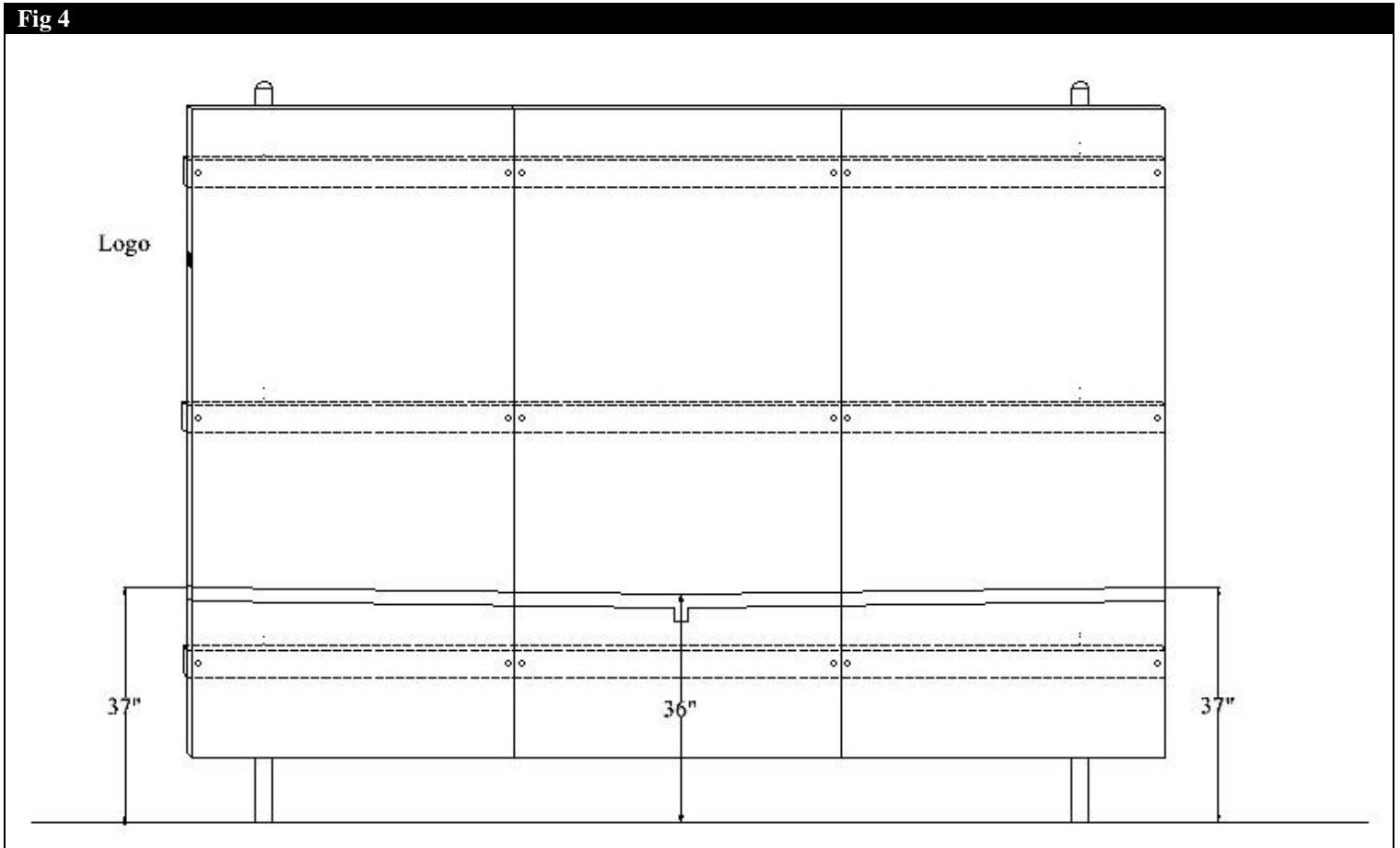

## **PARTS LIST 8' x 12' ECONOMY FLAT SERIES**

- (3) 4' x 8' Fiberglass Panels**
- (3) 12' Pressure Treated 2 x 4's**
- (1) Small Box of Hardware Containing:**

### **SMALL HARDWARE BOX:**

- (18) 3/8" x 4" "Color Matched" Flat Head Carriage Bolt, Nut & Washer
- (12) 3/8" x 8" Carriage Bolt, Nut & Washer
- (6) Back Post Braces
- (1) 13' Roll White Trim Tape
- (1) Bak Bord Logo
- (1) Roll Weather Stripping

### **TOOLS REQUIRED FOR INSTALLATION**

- **CORDLESS DRILL OR ELECTRIC DRILL WITH LONG EXTENSION CORD TO REACH POWER WITH 7/16" BIT. BE VERY CAREFUL! DO NOT USE FAULTY EQUIPMENT OR WHEN WET, AVOID ELECTROCUTION!!!**
- **WRENCHES-- DEEP THROATED SOCKET WRENCH REALLY HELPS, 9/16"**
- **LARGE HAMMER & BLOCK OF WOOD**
- **2 LADDERS ( put flat boards or cardboard under ladder feet to prevent damage to court)**
- **TAPE MEASURE**
- **LARGE SCREWDRIVER OR PRY BAR**
- **HACKSAW**
- **LONG FLAT BOARDS & CINDER BLOCKS (or materials for temporary platform)**
- **SCISSORS OR SHARP KNIFE**
- **4' LEVEL FOR PLUMBNESS OF 2 x 4's**
- **CLEAN CLOTH RAGS**

### **LABOR REQUIREMENTS**

**( 2 MEN; ONE SMART, ONE STRONG, 3 HOURS )**

### **ADDITIONAL INFORMATION**

**We suggest you hang a net or extend the fencing above your BAKKO BAK BORD to prevent miss hits from going over the fence.**

**Backboards of any kind are windscreens and should not be placed on flimsily built fences, especially those supported by "tubing" rather than standard weight (schedule 40) pipe as recommended in TENNIS COURTS published by the UNITED STATES TENNIS ASSOCIATION. We recommend these posts be a minimum 2&1/2" to 3&1/2" OD sunk in a concrete well 12" in diameter, 36" deep. Posts of this type, spaced 10' on center, usually provide quite adequate support.**

**Should your panels become damaged, they can be patched or completely painted with IMRON paint, color # 7666, sold by DuPont Nemours & Co. – a DuPont distributor. Deep panel injury requires a fiberglass experienced repair technician. Call us if further help is needed.**

# SUPPLEMENT INSTRUCTIONS FOR ECONOMY SERIES

If you feel the backboard is too loud for your area, appropriate sized wooden wedges may be cut and inserted between 2x4's and panel backs to reduce vibration noise. Cut wooden wedges to dimensions specified below. Place wedges between 2x4's and panel backs as shown. More wood wedges will decrease vibration (noise). Drive wedges down carefully from behind fence mesh. Do not drive wedges too far causing panels to bulge.

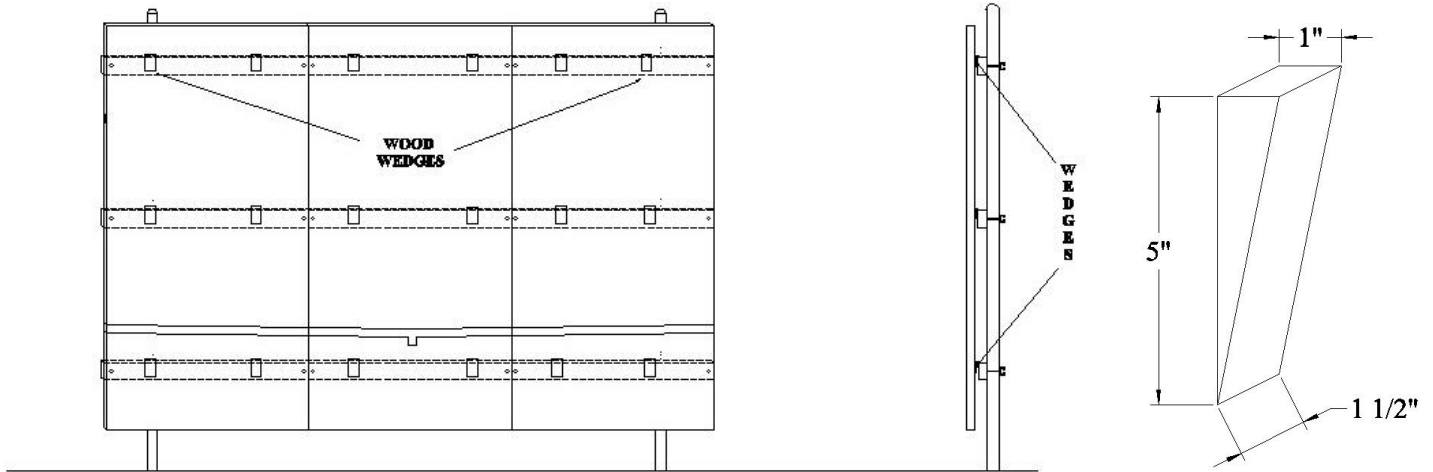

Use caution when selecting preferred fence location. In the sun belt, the backboard should not face the West due to intense sun. This probably will accelerate aging of panel surface and paint. Ideally the panels should be at right angles to the path of the sun so during practice a player never directly looks into the sun. If placed on a tennis court end, the white lines of the court may be used as practice reference points/lines.

