

4', 6' OR 8' FLAT BENCH - SURFACE MOUNT

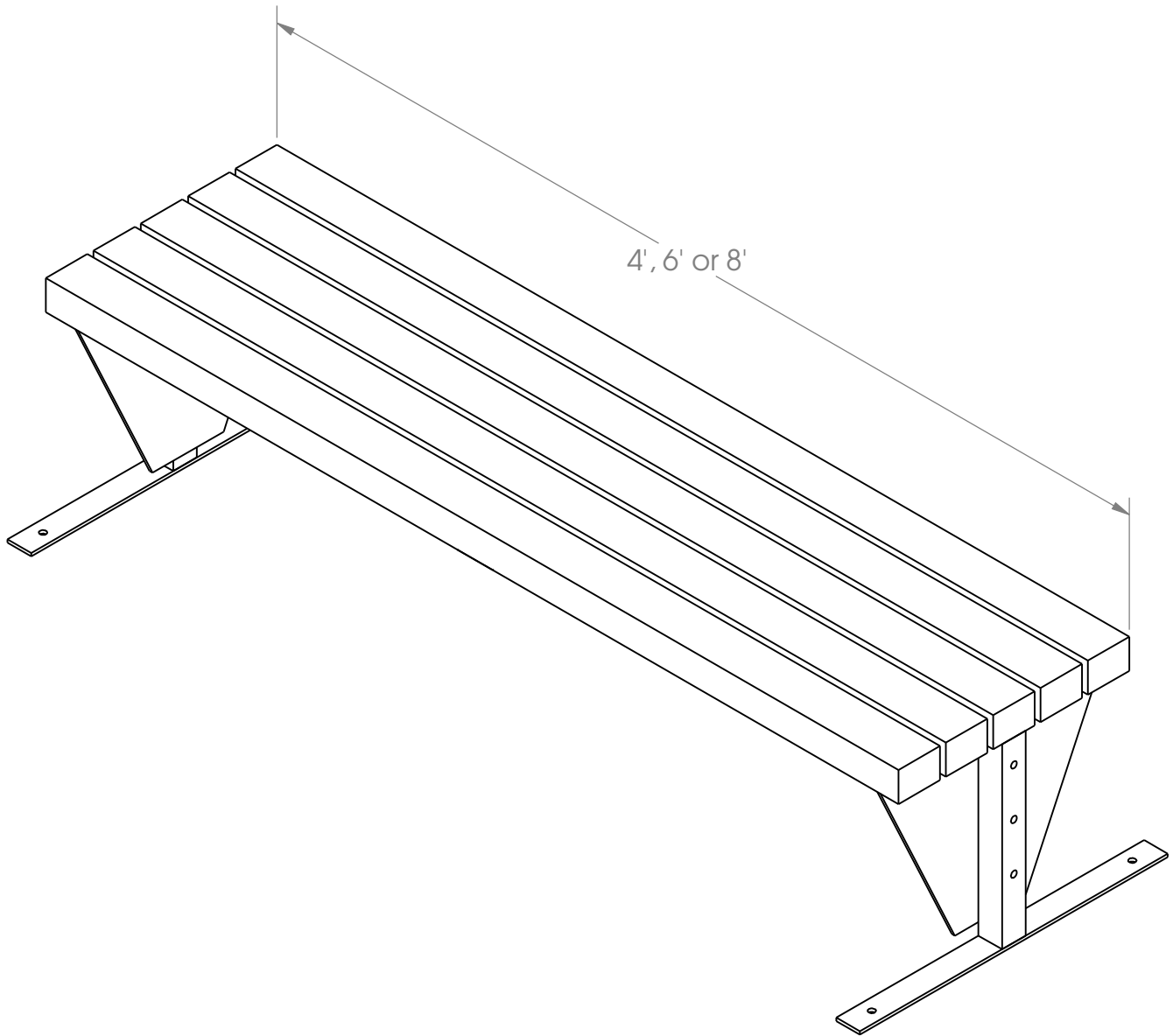

4', 6' or 8'

PROPRIETARY AND CONFIDENTIAL

THE INFORMATION CONTAINED IN THIS DRAWING IS THE SOLE PROPERTY OF SUNTRENDS INC. ANY REPRODUCTION IN PART OR AS A WHOLE WITHOUT THE WRITTEN PERMISSION OF SUNTRENDS INC. IS PROHIBITED.

ISOMETRIC VIEW

SunTrends, Inc.

P.O. BOX 101057
DENVER, CO 80250
303-744-2647

SCALE 1:14

SHEET 1 OF 5

4', 6' OR 8' FLAT BENCH - SURFACE MOUNT

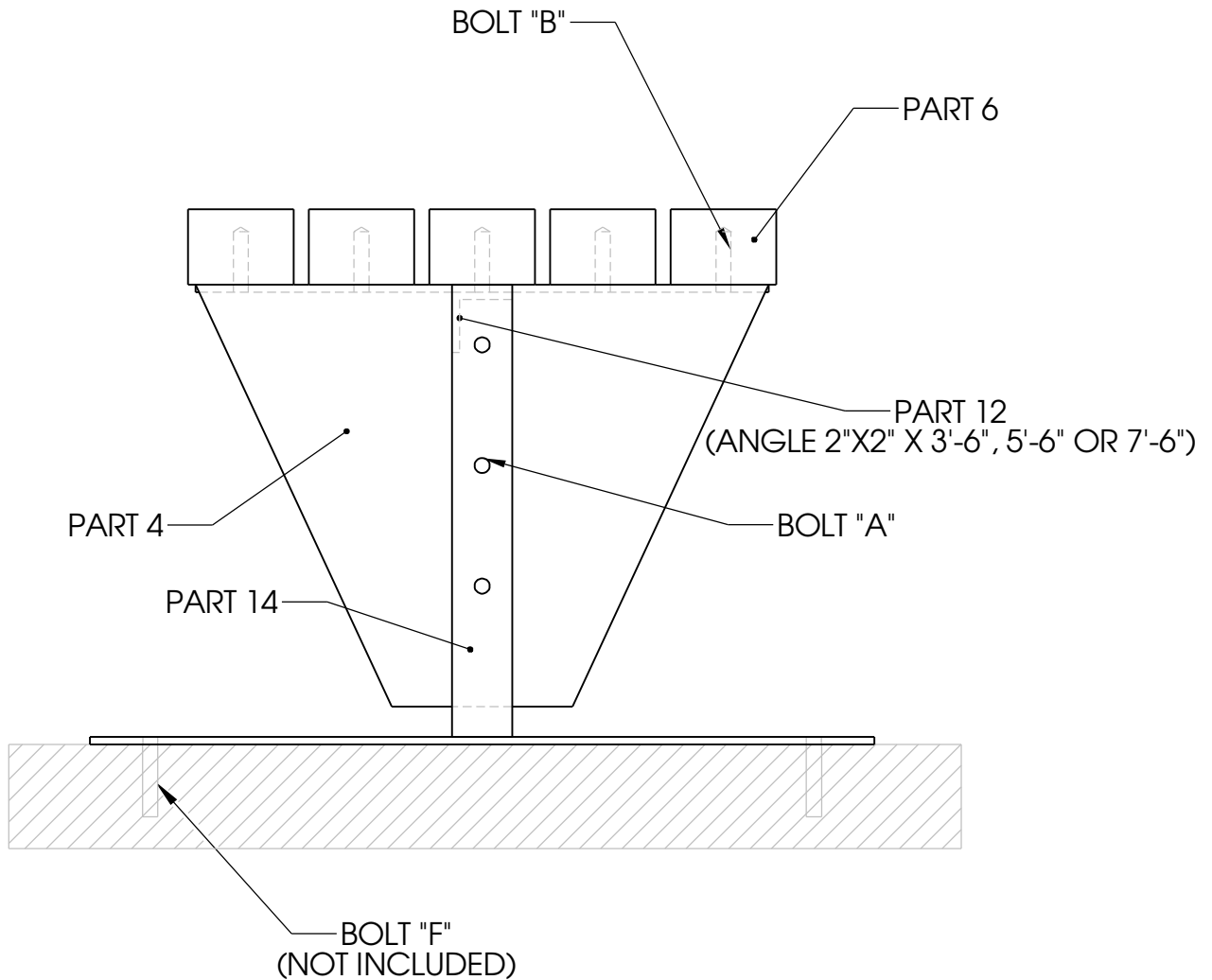

SIDE VIEW

SunTrends, Inc.

P.O. BOX 101057
DENVER, CO 80250
303-744-2647

SCALE 1:14

SHEET 1 OF 5

PROPRIETARY AND CONFIDENTIAL

THE INFORMATION CONTAINED IN THIS DRAWING IS THE SOLE PROPERTY OF SUNTRENDS INC. ANY REPRODUCTION IN PART OR AS A WHOLE WITHOUT THE WRITTEN PERMISSION OF SUNTRENDS INC. IS

SolidWorks Student Edition for Academic Use Only

4', 6' OR 8' FLAT BENCH - SURFACE MOUNT

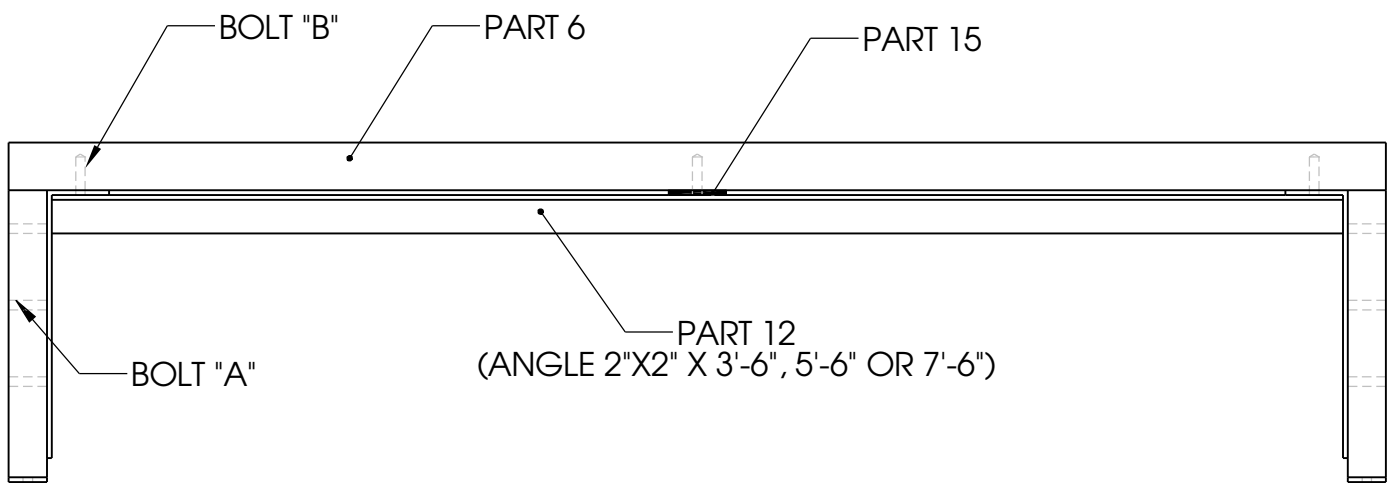

FRONT VIEW

PROPRIETARY AND CONFIDENTIAL

THE INFORMATION CONTAINED IN THIS DRAWING IS THE SOLE PROPERTY OF SUNTRENDS INC. ANY REPRODUCTION IN PART OR AS A WHOLE WITHOUT THE WRITTEN PERMISSION OF SUNTRENDS INC. IS

SunTrends, Inc.

P.O. BOX 101057
DENVER, CO 80250
303-744-2647

SolidWorks Student Edition for Academic Use Only

SCALE 1:14

SHEET 1 OF 5

Installation Guidelines

Flat Bench (4', 6' and 8')

Tools Needed: Ratchet set, wrenches (Roto-hammer needed for optional expansion bolts)

Step 1: Posts, Seat Plates & Angle Iron

Attach the (2) seat plates (Part #4) and (1) angle iron (Part #12) to the inside face of the (2) posts (Part #14) with bolts "A".

Step 2: Durawood Bench Slats

Secure Durawood slats (Part #6) to seat plates (Part #4) with lag bolts "B" (*Note – Bolt "B" will travel through angle iron (Parts #12), seat plate (Part#4), and into Durawood slat (Part#6) in that sequence).

Sand which bench strap (Part #15), at center of bench, between angle iron (Part #12) and Durawood slats (Part #6). Secure from the bottom with Bolt "B"

*Note – Center strap will rest on top of angle iron.

Step 3: Miscellaneous

Use can of black spray (semi gloss) paint to touch up scratches from shipping or erection.

PART AND BOLT SCHEDULE - FLAT BENCH

NUMBER	QUANTITY	DESCRIPTION
4	2	STEEL SEAT PLATE
6	5	3" X 4" NOMINAL DURAWOOD PLASTIC SLATS
12	1	2" X 2" ANGLE
14	2	3" X 3" POST WITH LEG
15	1	BENCH STRAP (3" wide x 19" long)
"A"	6	3/8" X 3.1/2" HEX HEAD BOLT W/ NUT & WASHER
"B"	15	3/8" X 2" HEX HEAD LAG SCREW W/ WASHER (ONLY QUANT. (10) FOR 4' BENCH)
"F"	4	1/2" X 3.1/2" EXPANSION BOLT (OPTION) NOT INCL.